

VandalVeto®

VF9-6545

Firm 9U Series

Solid as Rock

Flexible as Pebble

We strengthen the structure,
meanwhile keeping the flexibility.

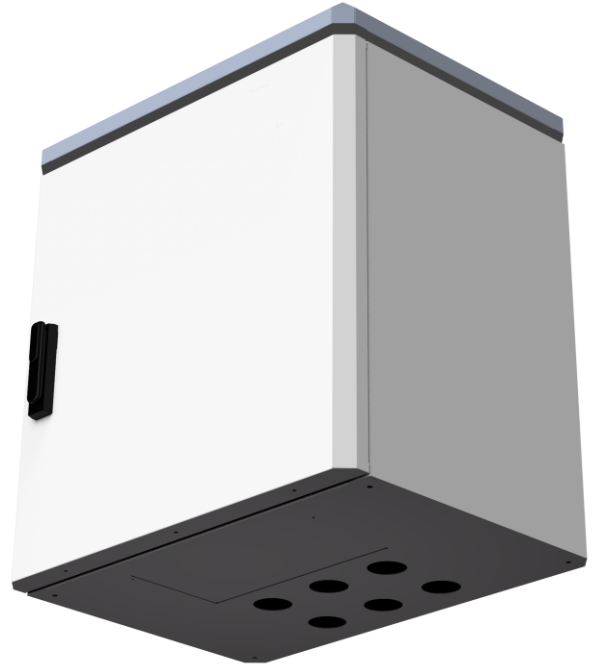

Rainproof



Ventilation



Heat dissipation



Anti-corrosion



Lightning Protection



Dustproof



Firm Structure



Modular Installation

≡ Application

This equipment cabinet is an all-weather outdoor electrical equipment protection box designed for outdoor use in the outdoor environment. It has waterproof, dustproof, ventilation and heat dissipation, anti-ultraviolet, anti-theft, anti-rust, acid and alkali corrosion, anti-electromagnetic interference (anti-lightning EMP), modular structure design in the box, electrical equipment can be installed vertically or horizontally according to the situation.

≡ Parameter

Satisfy the protection of weak current equipment in complex outdoor environments, The cabinet material and process have the ability to resist corrosion and electrochemical reactions; after degreasing, pickling, passivation, and phosphating, professional outdoor plastic powder is baked, which can make the paint layer in natural and unnatural environments The bottom has super anti-aging, gas corrosion resistance, UV damage resistance, acid and alkali corrosion resistance, salt spray humidity resistance.

The cabinet body can bear external pressure of more than 100KG without deformation.

VandalVeto®

Dimensions			
Model	Overall Size (W*H*D)	Inner Size (W*H*D)	Weight (kg)
VF9-6545	600*550*450mm	590*500*440mm	29

Standard Parameter			
Brand	VandalVeto	Thickness	1.5mm
Series	Firm	Material	SECC/Galvanized Steel
Name	Outdoor Cabinet	Color	Light grey+grey
		IP Level	IP55
Door	1	Electrical Install	Plate*2
Surface Treatment	Electrostatic Spraying	Installation	Pole/Wall Mounting
Function	Junction, Distribution, Electrical, Battery, Control, Monitoring etc. Outdoor waterproof cabinet		

Customizable Parameter	
Thickness	0.8mm, 1.0mm, 1.5mm, 2.0mm etc. any thickness
Material	SPCC/Cold Steel, SUS/Stainless Steel etc. any thickness
Color	Grey, Green or other colors
Protect Level	IP56, IP66, IP67, IP68 NEMA 4, NEMA 4X, NEMA 6, NEMA 12, NEMA 13
Electrical Install	Quick release plate, Double-swing door, Drawer structure etc.
More Custom	Surface printing design Industrial appearance design Structure design Whole system design

VandalVeto®

☰ Installation

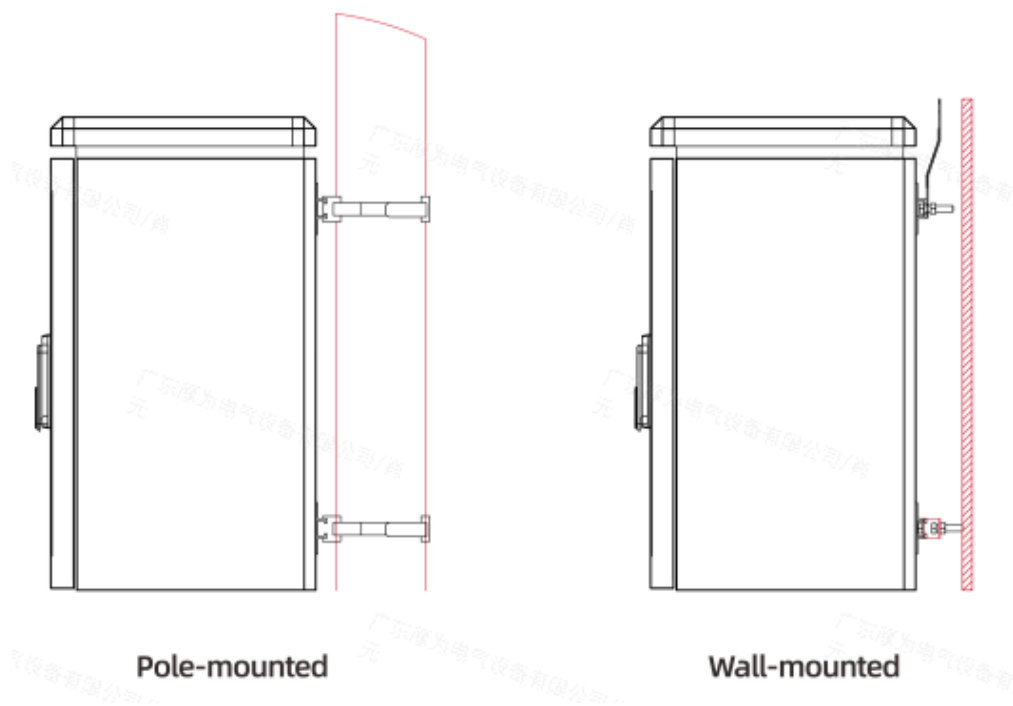

Different installation parts can be purchased for pole, wall or floor installation.

The same cabinet can meet the construction needs of different installation scenarios at the same time.

